

4120R 6 Zone Reader

Data Sheet

Ascendent ID's 6 Zone Reader provides the communication functions necessary to implement a long range radio frequency identification (RFID) system using Ascendent ID tags.

When running embedded application software on the internal Motorola MC68340 microprocessor, the interrogator manages all wireless communications with the tags.

The 6 Zone Reader can communicate with a broad range of user-selected external devices through multiple, configurable, industry standard serial interfaces.

A single Ascendent ID Reader provides the functionality of 6 separate single-zone readers, making it the perfect choice for toll plazas or large parking facilities with several adjacent lanes.

Variable data output format and available SDK ensure that Ascendent ID's readers and tags seamlessly integrate with most any application.

For more information about Ascendent ID's RFID readers and tags, visit us on the web at www.ascendentid.com

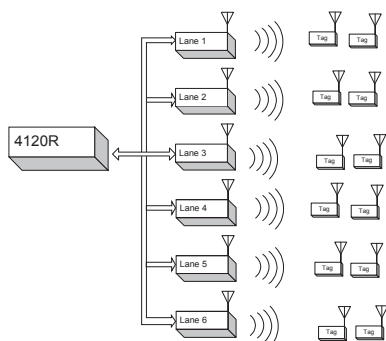

Typical Configuration

Features

- SDK library for custom application development
- Sophisticated reader-to-tag protocol provides a feature rich wireless communications platform
 - DES encryption option for high security applications
 - Reads hundreds of tags simultaneously using complex sorting algorithm
- Independent operation of each zone
- Adjustable output power for optimized read range
- Standard 26 Bit Wiegand output is compatible with most access control systems
- Integral support of tag commands including Tag Sleep, Tag Hush, Tag Battery Status, and more
- Return link collisions are minimized through the use of modulated backscatter (MBS) with 75 or 150 hopping channels, using a 596 kHz differential phase shift keyed (DPSK) modulated subcarrier
- Forward link is direct sequence spread spectrum (DSSS) with center frequency of 2.442 GHz
- Includes up to 3 transmit and 3 receive RF ports
- Antenna ports may be used for antenna diversity or multiple read zones.
- 3 standard serial ports:
 - 1 dedicated RS-485 port
 - 2 ports configurable for RS-232, RS-422, or RS-485
- Auxiliary digital port with 8 application-configurable input/output lines (TTL levels)
- RF output power programmable in 1 dB steps



Specifications

Microprocessor

Motorola MC68340

Memory (Bytes)

Flash: 1 MB - contents upgradeable from field

EPROM: 128 KB - socket accepts devices to 512 KB

SRAM: 1 MB no-wait state static RAM (a small portion of this memory is used by the system)

Physical Dimensions

4.28 x 6.8 x 6.64 in (10.7 x 17.0 x 16.6 cm)

Operating Temperature

-40 to +185 °F (-40 to +85 °C)

Humidity

95% non-condensing

Vibration

7 Grms all axes

Shock

Operates properly after 3-foot drop onto concrete

Power Requirements

VDC: +8.0 to +9.0 VDC at 2.0 Amps (typical)

-8.0 to -9.0 VDC at 0.5 Amps (typical)

12V DC UL approved Power Supply available

RF Output Power (max)

TX1: 28.0 dBm \pm 2 dB @ 77°F (25 °C)

TX2, TX3: 27.0 dBm \pm 2 dB @ 77°F (25 °C)

Over -40 to +85 °C all tolerances increase to \pm 3 dB

Programmable in 1 dB steps down to +5 dBm

(8.5 dB gain antenna and > 3' cable required for operation)

RF Ports (TNC socket)

Option 1: • 3 RF Transmit Ports

- 3 RF Receive Ports

Option 2: • 6 RF Transmit Ports

- 6 RF Receive Ports

RF Port Isolation:

Between TX1, TX2, TX3 10 dB (min)

Between TX4, TX5, TX6 10 dB (min)

Between TX1-3 and TX4-6 30 dB (min)

All RX ports 20 dB (min)

Receive Sensitivity:

-90 dBm @ 77 °F (25 °C)

System Interfaces

- 2 serial ports for use with RS-232, RS-422, RS-485, or TTL line drivers
- 1 serial port for use with RS-485 mode only
- 8 TTL-compatible auxiliary lines to control lights, relays, gates, etc.
- 5 LEDs: 1 power, 1 transmit, 1 receive, 2 available for user control
- 2 analog-to-digital converter input ports (0-5 volts)
- 4 Wiegand (26 bit) interfaces

Interface Connector

37-pin filtered D-sub miniature connector (pins on unit)

Application Development

Custom software can be developed with provided SDK

Standard Development Kit (SDK) includes:

- rfAID.exe, an application designed to familiarize the user with available reader and tag functions and commands
- API Library (available for RFID-related tasks)
- Example programs
- 4100 utility library with source code (available for MC68340 related tasks)
- Developer's web-based training documentation

Read Rate

Up to 25 reads per second

Regulatory Certification

UL 60950-1

CAN/CSA-C22.2 No. 60950-1-03

FCC Certification (Part 15) - Unlicensed operation

FCC approval is contingent on the use of specific antennas provided

by Ascendent ID

Professional installation of this product is required

This device complies with Part 15 of the U.S.A. FCC Rules. Operation is subject to the following two conditions: (1) This device may not cause harmful interference, and (2) this device must accept any interference received, including interference that may cause undesired operation.