

Applications

- » Vehicle access control (AVI)
- » Toll Roads
- » Automated Fueling

- Ascendent ID's CompacTag™ tag is part of a high-performance radio frequency identification (RFID) system. The tags are designed to be mounted to a windshield or the back of a rear view mirror using double-sided tape or velcro.
- Ideal applications include vehicle access control (AVI), automated fueling, toll roads, and asset tracking.

Features

- 2.45 GHz operating frequency
- Remote access to data
- Long range
- Spread spectrum operation
- Safeguarded data
- Spread spectrum communications
- Durable
- 256 bytes of read/write user memory
- Partitionable memory

Benefits

- Enables data collection in a well-defined zone
- Hands-free operation and increased automation of processes provide operational cost savings
- Up to 40 feet read/write range in typical application installations
- Reduces interference in electronically noisy environments for increased communications dependability
- Prohibits unauthorized use of information stored in tag memory
- Reliable communications in electrically noisy environments
- Withstands hot and cold temperatures as well as dirty, oily, and harsh environments
- Operates as a portable database permitting user data to be stored and modified on the tag remotely
- Flexible system design allows multiple levels of access to asset data

Ascendent ID offers a full range of RFID solutions with specific market focus on vehicle access control (AVI), yard management, Toll Roads, load tracking, and commercial fueling.

For more information about how Ascendent ID's RFID technology can benefit your business, visit our web site at www.ascendentid.com.



Parameters

Operating Frequency	2.400-2.483 GHz
Nominal Read/Write Range ¹	40 ft (13 m)
Typical Read/Write Range ²	30 ft (10 m)
Physical Dimensions	2.2 x 1.31 x .28 in (5.59 x 3.34 x 0.72 cm)
Weight	0.46 oz (13 g)
Operational Temperature	-4 to +140°F (-20 to +60°C)
Storage Temperature	-40 to +140°F (-40 to +60°C)
Service Life ³	4 years (nominal)
Battery Type	Lithium battery
Case Material	PC/ABS

Specifications

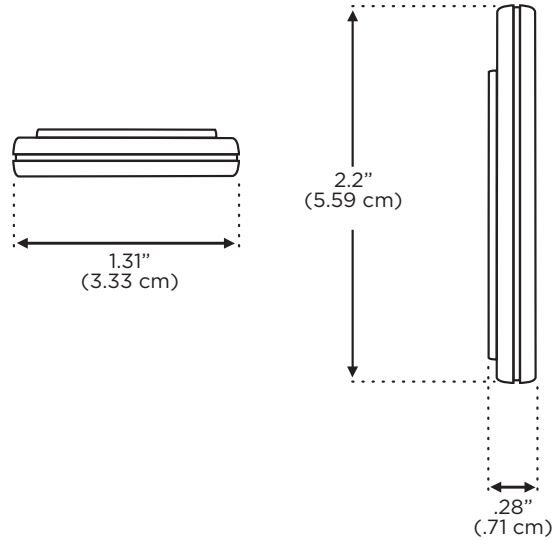

CompacTag™ 2230 Dimensions

1. Nominal Read/Write Range is typical average line-of-site range of the tags when illuminated at the US FCC allowable power level of +36 dBm (28 dBm into a 8.5 dB gain antenna and > 3' cable) in an anechoic chamber with optimum antenna polarization match. (Actual performances will vary depending upon ambient conditions and power level.)
2. Typical Read/Write Range is average line-of-site range of the tags when installed in a typical application. (Actual performance will vary depending upon ambient conditions and power level.)
3. Service life specified under typical usage conditions (average transactions per week of 1,000 or less; 16ms wake-up period).

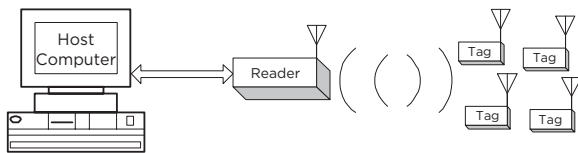

Typical Configuration

A typical system configuration includes a host computer, a reader, and RFID tags.



3640 S. Cedar St., Suite M
Tacoma, WA 98409

t 253.238.0740
f 253.238.019